

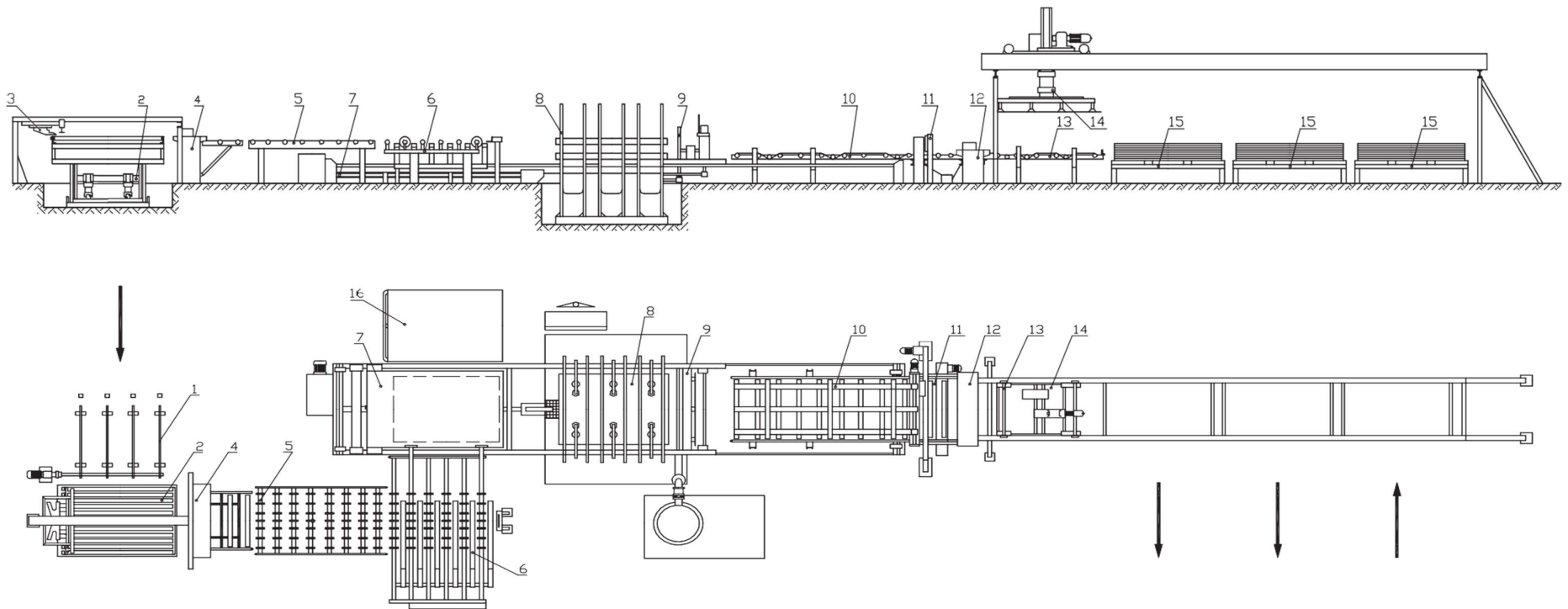

PLANT FOR PROCESSING PLYWOOD

45.23/10.4.1



Purpose: chip plates laminating.

- | | |
|----------------------------|-------------------------|
| 1. Ground conveyor | 9. Output conveyor |
| 2. Hydraulic lifting table | 10. Centering conveyor |
| 3. Board pusher | 11. Trimming machine |
| 4. Cleaning machine | 12. Cleaning machine |
| 5. Disc conveyor | 13. Centering conveyor |
| 6. Fork conveyor | 14. Stacking device |
| 7. Input conveyor | 15. Panel keeping table |
| 8. Hydraulic press | 16. Paper keeping table |

Main technical data:

Heating plates size	2200 x 2900 [mm]	On request
Size of finished panels	2050 x 2750 [mm]	
Specific pressing pressure	max 270 [N/cm ²]	
...	...	